

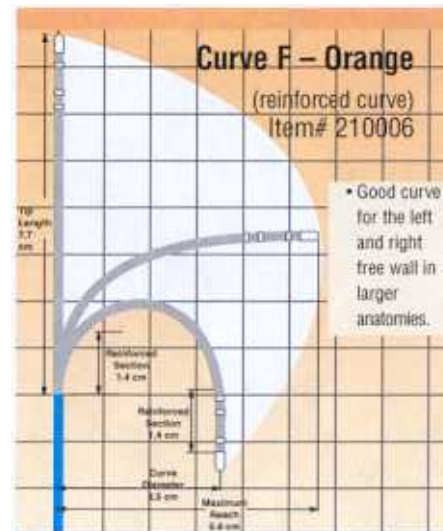

Curve Chart

with recommended usages

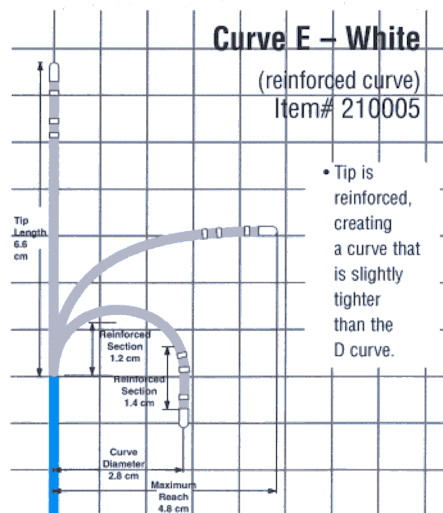
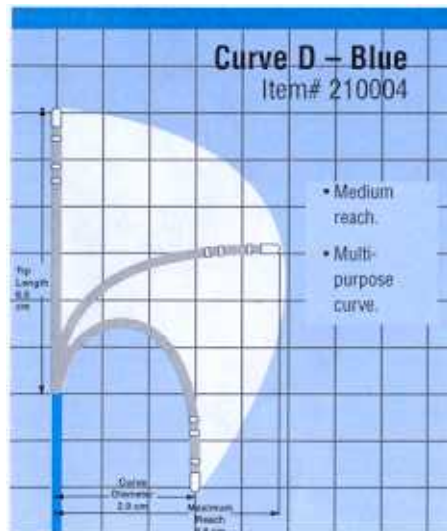
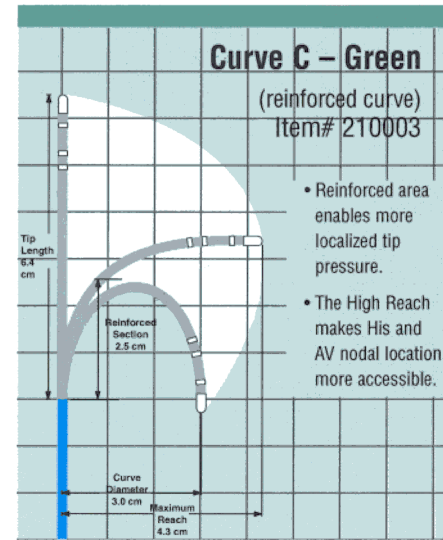
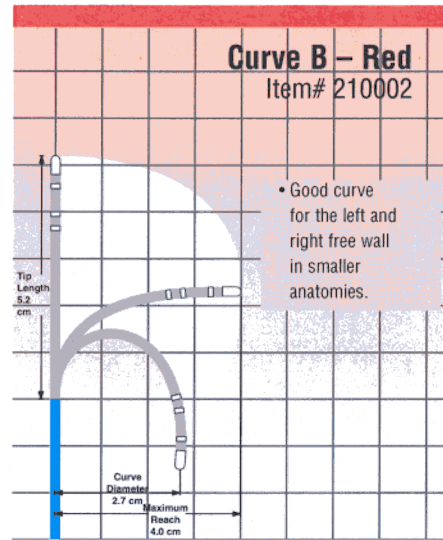
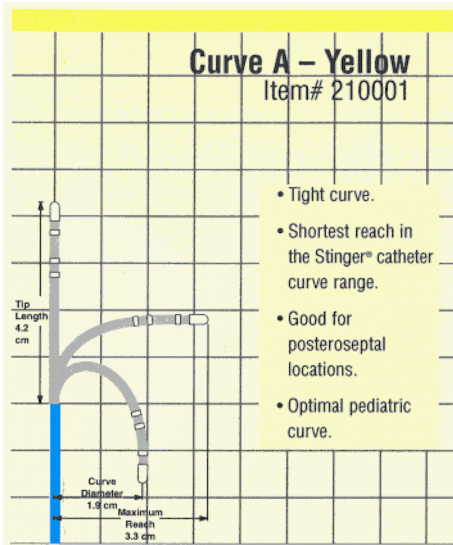

Tip Length – The length of the flexible section.

Maximum Reach – In a deflected tip, the perpendicular distance between the shaft and the distal electrode.

Reinforced Curve – (Curve C, E, F, G) – Curve with varying firmness along the steerable sections. The reinforced sections are firmer than the unreinforced section, enabling more localized tip pressure.

